

## FE 50 R/L X MAGNETIC DRILLING MACHINE

Left/ Right option

**FE 50 R/L X magnetic drilling machine**, versatility in a compact form. The exchangeable Morse taper 2 makes this magnetic drilling machine an all-round machine for all drilling purposes. The variable speed and right/left option enable this magnetic drilling machine to also be used for tapping / threading up to M16, reaming and countersinking. This machine is standard supplied with auto coolant system cleverly on top of the machine. This magnetic drilling machine is powered by a strong 1150 watt Eibenstock motor.

Motor power	1150 watt
Spindle	MT2, 19 mm (3/4") Weldon
Hole cutter (short 30 mm)	Ø 12 mm - Ø 50 mm (1-1/4")
Hole cutter (long 55 mm)	Ø 12 mm - Ø 50 mm (1-1/4")
Twist drill	Ø 23 mm (7/8")
Tapping	Ø M5-M16
Countersinking	Ø 40 mm (1-9/16")
RPM (variable)	150-250 min-1 / II 180-450 min-1
Stroke	160 mm (6.29")
Weight	13 kg (26.8 lbs)
Magnet power	1500 kg (3304 lbs)

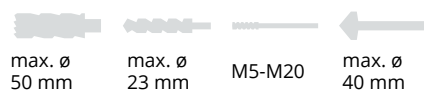

### MEASUREMENTS

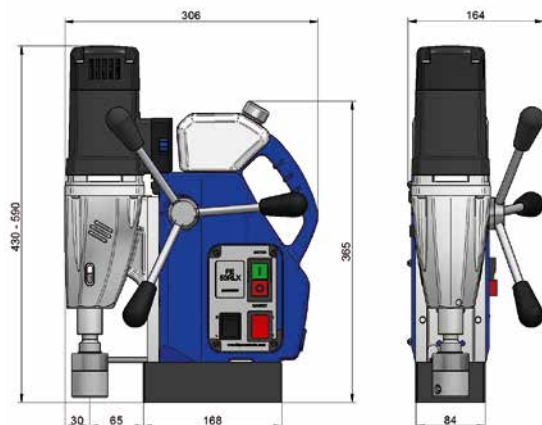

### STANDARD DELIVERY OF MAGNETIC DRILLING MACHINE FE 50 R/L X CONTAINS:

- |                             |                             |
|-----------------------------|-----------------------------|
| 1 mag drill                 | 1 adaptor B16-Morse taper 2 |
| 1 Morse taper no 2          | 1 tapholder M10             |
| 1 pilot pin (Ø 6.35×79 mm)  | 1 tapholder M12             |
| 1 pilot pin (Ø 6.35×103 mm) | 1 tapholder M16             |
| 1 Morse taper no 2 remover  | 1 safety strap              |
| 1 Strong PP carrying case   | 1 manual/ safetyguidelines  |
| 1 drill chuck               | Cutting oil 0.25L           |