

## FE 60 R/L X MAGNETIC DRILLING MACHINE

Left/ Right option

The new **FE 60 R/L X magnetic drilling machine** is multi-task drilling machine, light in weight with MT3 ! Designed to, not only drill with hole cutters and twist drills, but also to be used for tapping / threading up to M20. This machine is supplied with auto coolant system. This magnetic drilling machine is powered by a strong 1600 watt Eibenstock motor.

All our mag drills can be supplied in 110 Volt as well as in 230 Volt.

Motor power:	1600 Watt
Spindle:	MT3, 19 mm (3/4") Weldon
Hole cutter/annular cutter short 30mm:	Ø 12 mm - Ø 60 mm (1-1/4")
Hole cutter/annular cutter long 55 mm:	Ø 12 mm - Ø 60 mm (1-1/4")
Hole cutter/annular cutter extra long 75 mm:	Ø 20 mm - Ø 60 mm (1-1/4")
Twist drills:	Ø 25 mm (1")
Tapping:	Ø M5-M20
RPM variable:	I 70-280 min-1 / II 180-580 min-1
Stroke:	160 mm (6.29")
Weight:	15 Kgs (26.46 Lbs)
Magnet power:	1500 Kg

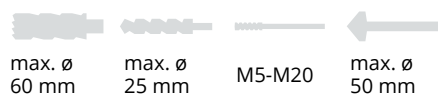

### MEASUREMENTS

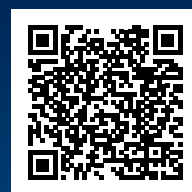
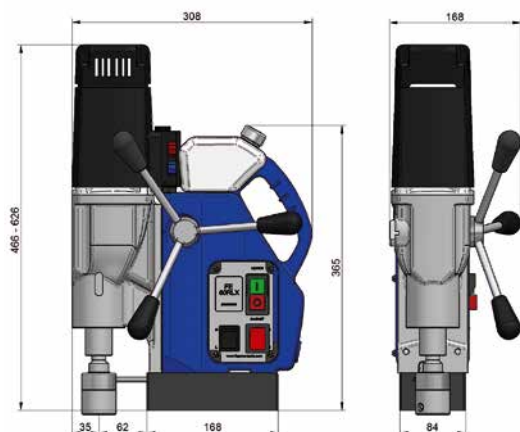

### STANDARD DELIVERY OF MAGNETIC DRILLING MACHINE FE 60 R/L X CONTAINS:

- 1 mag drill
- 1 pilot pin FEPP 75 (Ø 6.35×79 mm)
- 1 Allen key 4
- 1 tapholder DIN 376 M10
- 1 tapholder DIN 376 M12
- 1 tapholder DIN 376 M16
- 1 PP carrying case
- 1 safety strap
- 1 manual/ safety guidelines
- Cutting oil 0.25L